



HID Xenon & LED Lighting Technology for Aerospace, Military and Industry

---

## **XePulse™2 with SPM ballast wiring Instructions (Mar 10, 2014)**

### Description and Remarks:

Pulsing (wig-wag) of one or more channels (HID lights) comprises either ON-OFF or High-Low switching of the lights by means of the XePulse 2. This document focuses on ON-OFF wig-wagging with our SPM (single power mode) ballasts.

The HID ballasts (HID lights) are powered directly from the aircraft power source through an existing main switch (or by means of a relay) with appropriate CB for the ballasts and adequate ground. The XePulse 2 is an added separate circuit with its own CB. The XePulse 2 cannot be used to power any HID ballasts, the XePulse 2 only provides a low-level trigger signal to switch (pulse) the ballast ON-OFF using our Single Power Mode ballasts (SPM).

Only HID XeVision ballasts (SPM) with a 3-pin connector are pulsing capable by means of the XePulse 2. The 3<sup>rd</sup> pin is the trigger pin for pulsing controlled by the XePulse 2.

Two installation options (A, B) are recommended to wire the XePulse 2 with one, or two output channels for synchronized ON-OFF pulsing

Make sure the XePulse 2 is properly grounded, otherwise the pulsing output signal will stay on and therefore the HID lights will remain turned off.

Important: Each time the XePulse 2 module is selected for pulsing, there is a programmed time delay of 30 seconds before pulsing is activated while the light(s) is powered. This ensures that the HID bulb has reached steady state condition before pulsing.

### **Installation wiring A:**

A switch (low current) is used for switching the XePulse 2 module ON or OFF. The way to do this is to install the switch between the aircraft power source (with 1 amp CB) and the pin 1 of the XePulse 2 module. Pin 2 is the aircraft ground connection. The XePulse 2 5-VDC contact must be permanently jumpered to the pulsing contact (connect pin 5 and pin 6), and the 'continuous' contact, pin 4, is unused.

With this setup, pulsing is accomplished by switching the power to the XePulse 2 ON. In the OFF position the HID lights are continuously ON, meaning that the HID ballasts are powered on, controlled by the main 'landing light' switch or switches set to ON.

# XeVISION™

HID Xenon & LED Lighting Technology for Aerospace, Military and Industry

## Installation wiring B:

This is based on using an external 3-way low current switch (switch not part of the XePulse 2 shipment) wired directly from the XePulse 2 for completely controlling the HID ballasts (HID lights) operation. A main switch may or may not be needed.

A 5-VDC signal is generated by the XePulse 2 that is used to select CONTINUOUS ON, PULSING or OFF depending on the 3-way switch position. The 5-VDC signal (XePulse 2, pin 5) is routed to the center contact of the switch. Pin 4 and pin 6 are wired to the remaining 3-way switch contacts. The center position of the switch will turn the HID ballasts off.

Note: If there is no power to the XePulse 2 and there is power from the main aircraft system to the ballasts then the HID lights are on.

## Wiring schematic:

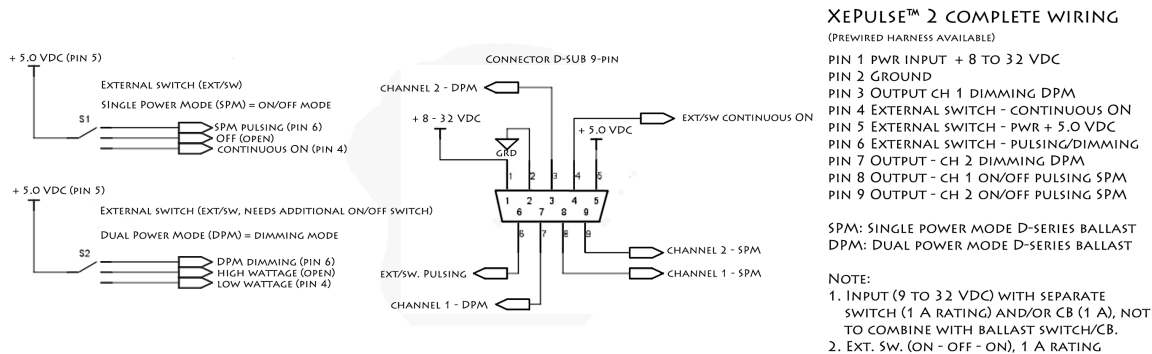

## Wire harness (optional) color code and XePulse 2 pin assignment:

Red	pin 1
Black	pin 2
White	pin 3
Brown	pin 4
Gray	pin 5
Blue	pin 6
White	pin 7
Yellow	pin 8
Yellow	pin 9

## XeVision SPM ballasts (single power mode ballast for ON-OFF operation)

Pulsing output	channel 1	Yellow	pin 8
Pulsing output	channel 2	Yellow	pin 9